

Flanged Bearing Housing

Series I-1200(00)

for self aligning ball bearing with extended inner ring

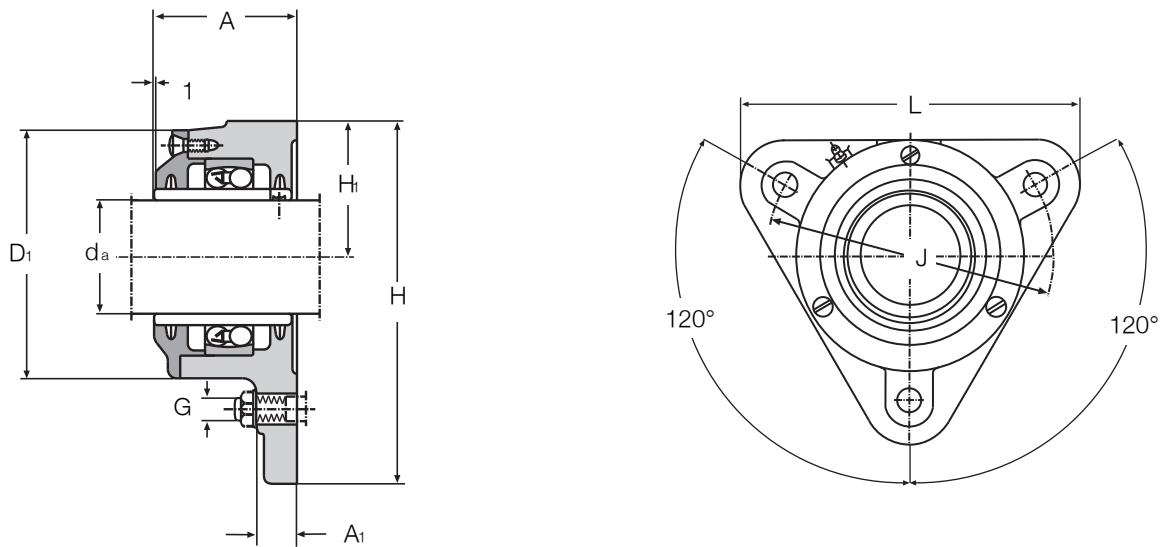

I-1200(00) - Flanged Bearing Housing

This range of flanged bearing housings is fitted with self aligning ball bearings with extended inner ring (series 112).

The outer ring of the bearing is located axially by means of a bolted on cast cover.

Flanged bearing housings series I-1200 are fitted with felt strip seals and are suitable for grease lubrication. A R1/8" grease hole is incorporated for eventual later greasing.

I-1200 flanged bearing housings are manufactured from grey cast iron.

Housing Ref	Matching Bearing	Weight kg	da	D ₁	H _i	H mm	A	L	A ₁	J	G
I-120013	11204	0,80	20	67	35	93	42	105	10	90	M10
I-120014	11205	0,99	25	73	38	100	46	110	10	96	M10
I-120015	11206	1,42	30	84	44	117	50	130	12	116	M10
I-120016	11207	1,78	35	95	48,5	130	54	145	12	130	M12
I-120017	11208	2,27	40	105	54	143	60	160	12	140	M12
I-120018	11209	3,33	45	115	60	160	63	180	15	160	M12
I-120019	11210	3,65	50	115	60	160	63	180	15	160	M12